

# **TRANSPRO<sup>®</sup> MUG**

## **HEAT PRESS USER'S GUIDE**

**MP996**

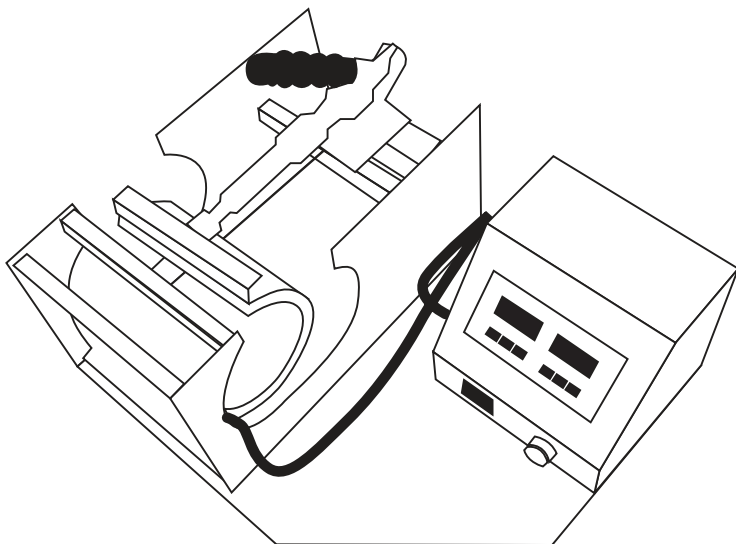

**PRO WORLD<sup>®</sup>**  
HEAT APPLIED GRAPHICS • PRESSES • ACCESSORIES

[www.ProWorldInc.com](http://www.ProWorldInc.com)

Pro World Inc.  
961 Bethel Ave.  
Pennsauken, NJ 08110

Toll Free 800-678-8289  
Outside U.S. 856-406-1020  
Fax 856-406-1025

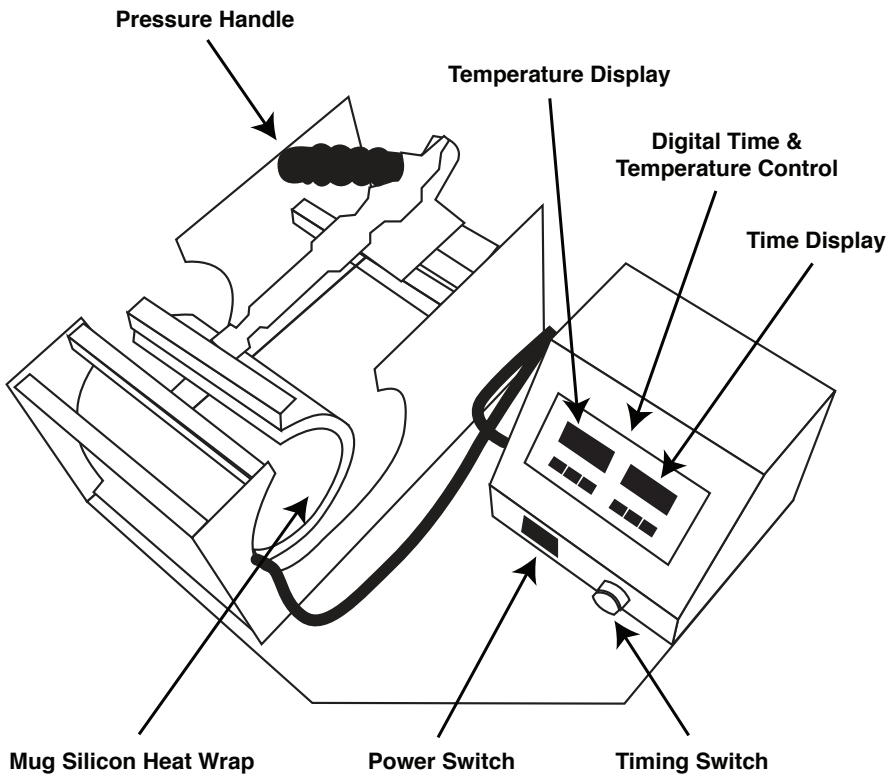

### **Specifications**

Model No: TransPro Mug MP996

Voltage 110v

Watt: 350 W;

Temperature Range: 0- 399 Celsius / 0-750 degrees Fahrenheit

Temperature control: Adjustable

Weight: 10kgs / 22Lbs

# OPERATION INSTRUCTIONS

## Read Before Operating

1. Be sure to operate with safe ground wire!!!
2. Check the voltage before using it. The correct voltage is 110-120v.
3. Turn off the machine when not in use.
4. Grasp the handle firmly when opening.
5. Keep children away from the machine.
6. Do not attempt to press products that are not intended for normal heat transfer use.

## Operation Procedures

1. Turn on the power switch and indicator light will display.
2. Adjust the temperature, the necessary temperature is within 180-200 Celsius / 356 - 392 Fahrenheit. Machine takes about 2 minutes to attain temperature.
3. Adjust the timer (usually about 120 seconds / 2 minutes).
4. Put design onto mugs according to directions with your transfer or transfer paper, please note that the image side is facing on to mug. The press will accommodate 11oz, 15oz, 16oz, mugs.
5. Pull the handle and place mug into the machine and then depress the pressure handle. The number on the temperature controller will decrease. Press the right green button, when timer beeps and mug is complete.
6. Press the green button again, after cooling for 1 minute then remove mug from the machine to dry and finish.
7. The machine will remain stable in temperature, it will rise to adjust.

## Adjustmentments

- Pressure: Adjust the tip of pressure handle to increase or decrease.
- Time: Adjust the Timer Controller button to proper time (120 seconds)
- Temperature: Adjust the temperature button to proper temperature 180-200 Celsius / 356 - 392 Fahrenheit
- Note: This machine uses a 2 in 1 temperature/ time controller.

## Suggestions

1. Turn off the machine for 2 minutes after one hour of use and then turn it back on to continue working.
2. When not in use, place a mug in slot and close the pressure handle in order to protect the pillow.

## Troubleshooting

1. Weak color after applying to mug usually means that the applied time is too short.
2. Picture is faint usually means that the time was too long and caused the ink to diffuse.
3. Part of the color is weak for the finished product usually means that the pressure is not enough or the sublimation coating is not adequate. Increase the pressure or change mug.
4. The finished product display is faint usually means that the pillow may need to be changed.
5. The picture has scar after being applied usually means the time is too long.

# WIRING SCHEMATIC

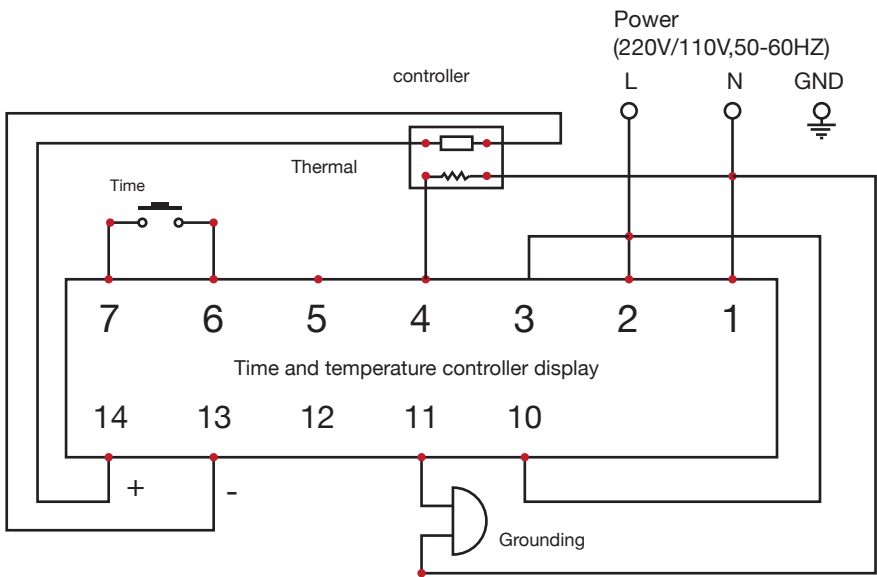

# TRANSPRO WARRANTY

## **Warranty Coverage**

TransPro products offered by Pro World are warranted against defects in material and workmanship. Warranty is void if equipment has been damaged by accident, unreasonable use, neglect, unauthorized and/or improper service, or other causes not arising out of defects in material and workmanship. This warranty does not cover damage caused by normal wear and tear, neglect or lack of proper maintenance.

## **Warranty Duration**

The heating element shall be warranted for the life of the mug press. There is a one (1) year warranty on major components, circuit boards and all other components.

## **Warranty Performance**

During the warranty period, and in the event that a situation cannot be resolved by telephone/email and upon PRE-AUTHORIZATION from Pro World equipment must be shipped, freight prepaid to Pro World for service in the original packaging. After 30 days, all shipping and insurance expenses to and from Pro World of in-warranty equipment is solely the responsibility of the customer. Prior to 30 days the shipping costs will be refunded if Pro World deems the equipment to be defective as stated. Pro World cannot be held responsible for improper handling or any other damage incurred in transit. No charge will be made for labor and components for repair of in-warranty equipment. OUT-OF WARRANTY machines will be charged at the repair rates in effect at the time the machine is received.

## **Warranty Disclaimers**

Pro World shall not be liable for loss of use of TransPro equipment or other incidental or consequential costs, expenses, or damages incurred by the original purchaser or any other user. The above warranty provisions constitute the entire agreement between all parties, and supersede any and all prior written and/or oral representations and understandings.

This "Limited Warranty" applies to all TransPro equipment. However, the procedure for obtaining service may vary outside the continental United States. Contact your Pro World representative for warranty information. The purchaser is responsible for compliance with all local laws, regulations and measure. Agreement shall be governed by and construed in accordance with all applicable laws of said region.



[www.ProWorldInc.com](http://www.ProWorldInc.com)

Pro World Inc.  
961 Bethel Ave.  
Pennsauken, NJ 08110

Toll Free 800-678-8289  
Outside U.S. 856-406-1020  
Fax 856-406-1025